



**THC3W High Energy Tantalum Hybrid Capacitor**  
(Hermetic sealed & Military standard)

**Characteristics and Applications**

All tantalum case, hermetic sealed, Cylindrical, radial leads, Polar, with screws, convenient to fix

This product is made up of tantalum capacitor and electrochemical capacitor

Stable electric performance, high reliability, long life, large energy density per unit volume,

Store much energy. Capacitance larger than THC2W.

Used as battery in Energy conversion circuit and power pulse circuit, Perform Energy storage, filter, power-off delay in circuit.

Standard: QJ/PWV358-2011

**How to order: THC3W-10V200000 $\mu$ F-M 100pcs**

**Technical Performance**

Temperature range: -55 ~+125 125 use derated voltage

Store environment temperature: -62 ~+130

Capacitance tolerance: K= $\pm$ 10% M= $\pm$ 20% Q= $-$ 10%~+30%

Electric performance: see table1



**Size and installation 36\*20/24 mm**

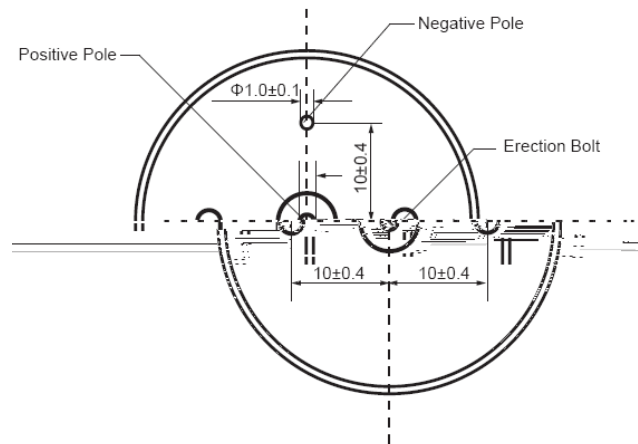
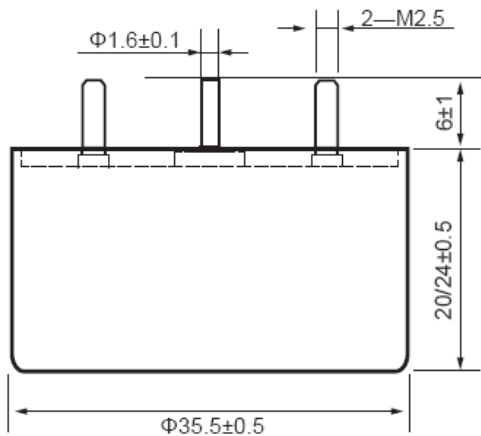

THC3W  $\Phi$ 36x20/24outline  
Unit:mm



Table1 THC3W High Energy Tantalum Hybrid Capacitor's data and size: 36\*20/24 mm

Rated Vol. (V)	Derated Vol. (V)	Surge Vol. V	Cap. $\mu$ F	tg $\delta$ (%) 100HZ	ESR $\Omega$ 1KHZ	LC./ $\mu$ A		R $\Omega$	Cap. change %		Case size	Weight
						25	85 125		-55	-55	+85	DxH mm
10	6	11	200000 230000	190	0.025	400	1800	1	-80	+160	36x20	